

Notes:

1. Embed all exterior metal surfaces in silica sand.
2. All reinforcing bars in reaction block shall be #4.

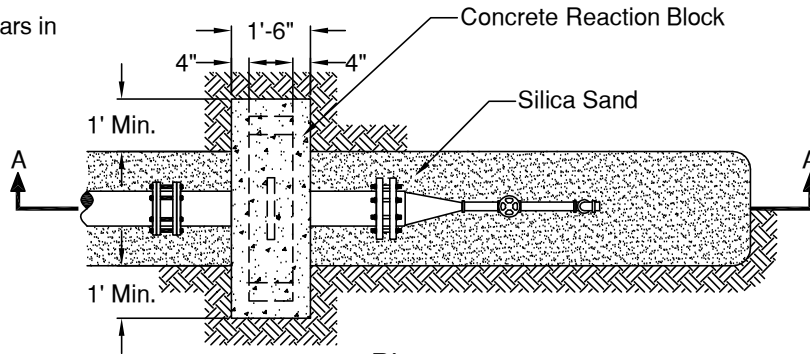

Plan

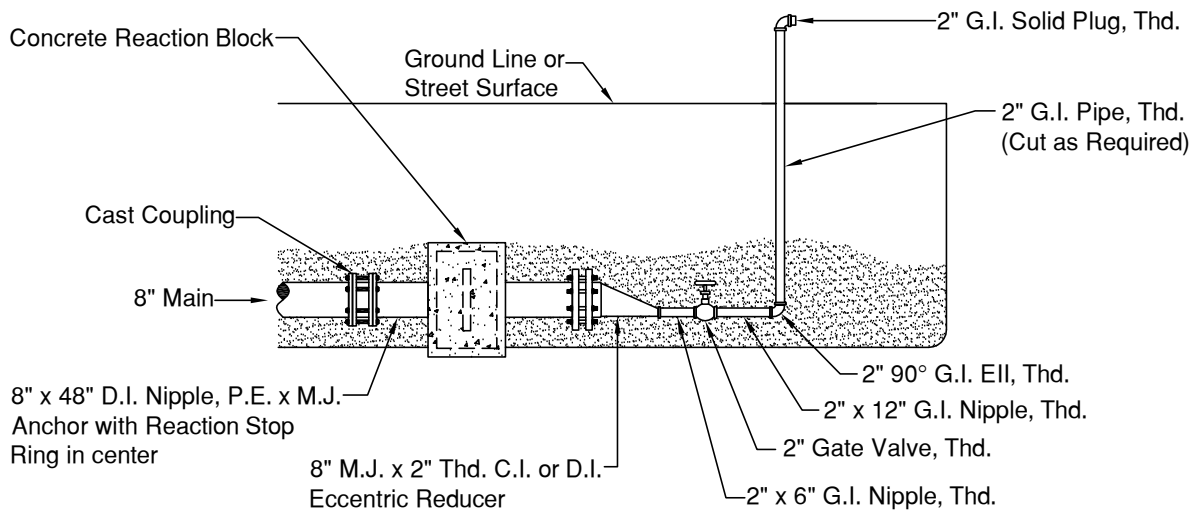

Section A-A

**2" TEMPORARY BLOW OFF ASSEMBLY
ON 8" P.V.C. OR D.I. MAINS**

Not To Scale