

- DETIAL A (1 EA.) 1/4" X 4" DIA. STEEL PLATE
- DETIAL B (1 EA.) 4" O.D. X 3 5/8" I.D. X 3" LENGTH STD. GALV. PIPE
- DETIAL C (1 EA.) 3 1/2" O.D. X 3" I.D. X 3'-11 3/4" LENGTH STD. GALV. PIPE
- DETIAL D (1 EA.) 3/8" X 12" STEEL ROD

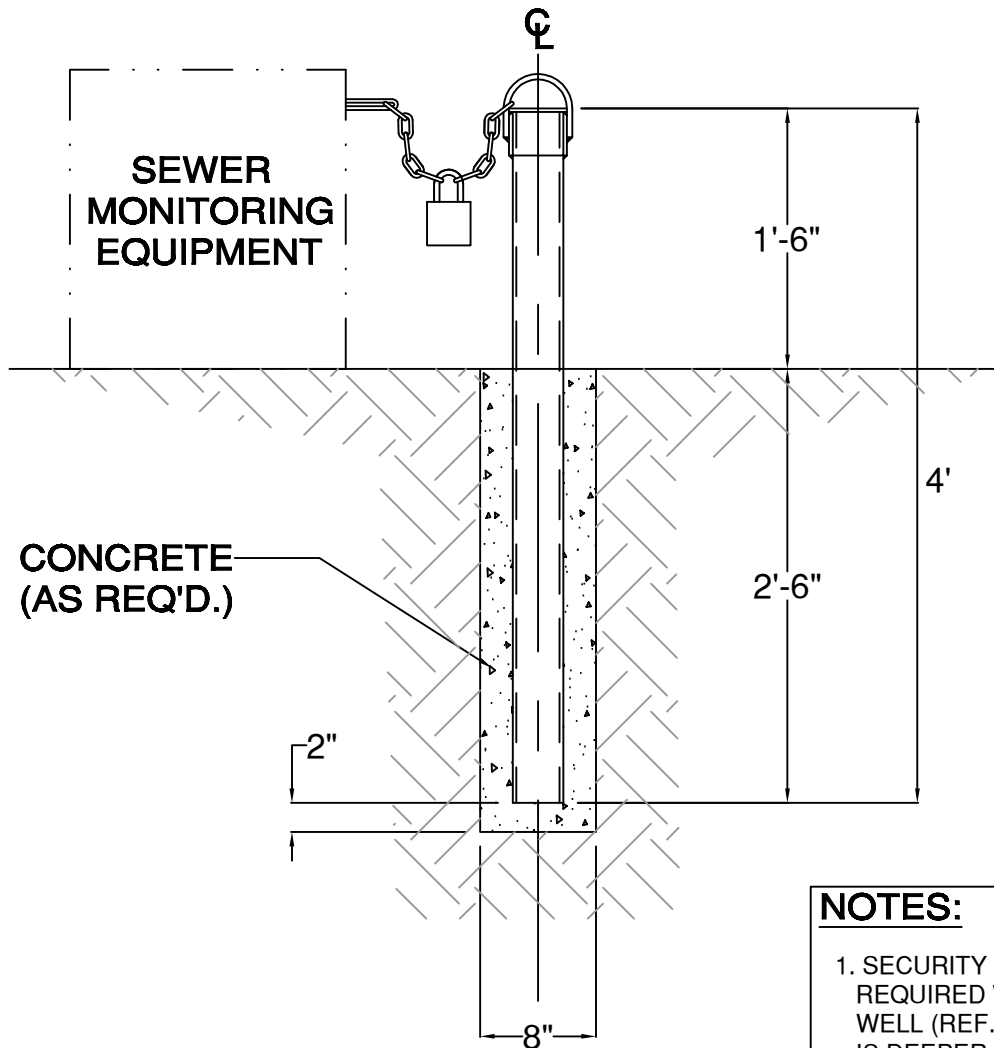

- NOTES:**
1. SECURITY POST WILL BE REQUIRED WHERE SAMPLING WELL (REF. DWG. 304) IS DEEPER THAN 5'-0"
  2. SECURITY POST TO BE LOCATED 1'-0" TO 2'-0" FROM SAMPLING WELL