

TOP VIEW

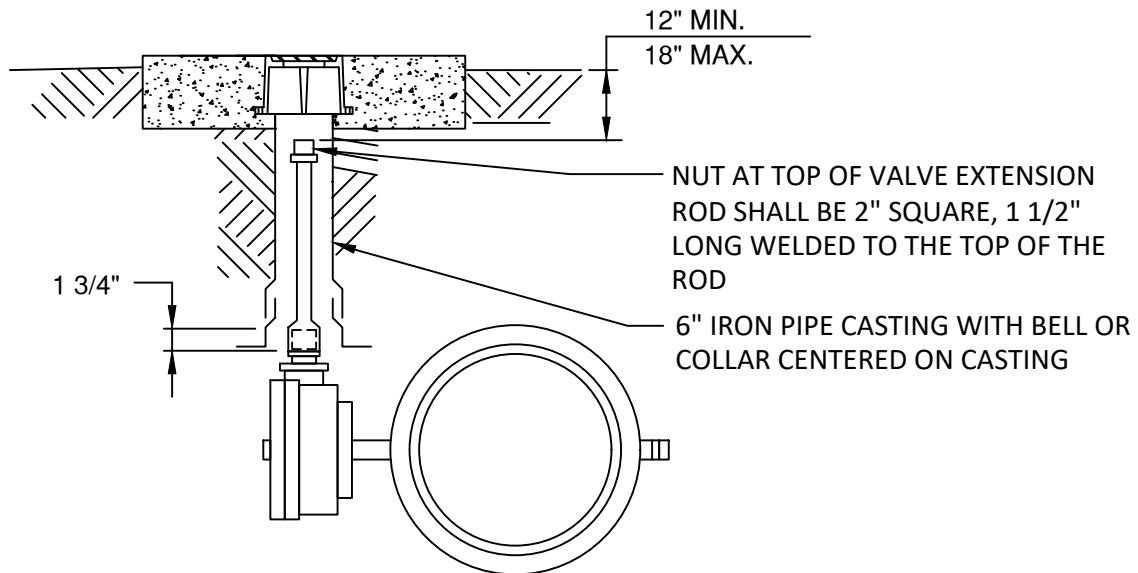

END VIEW

NOTES:

1. WELD SOCKET 2 5/8" X 1 1/4" DEEP TO 1 1/8" SOLID ROUND STEM EXTENSION.
2. NBU STANDARD VALVE BOX CASTING PAVING RING & LID. SEE DETAIL 232 AND 233.
3. ALL BUTTERFLY VALVES SHALL MEET THE REQUIREMENTS OF NBU SPL W8.1.0.



NEW BRAUNFELS UTILITIES
WATER SYSTEMS ENGINEERING

DRAWN BY:
EWL
APPROVED BY:
A. WILLARD
DRAWING DATE:
2/1/24

STANDARD DRAWING:

TYPICAL BUTTERFLY VALVE

UPDATED:

SCALE:

N.T.S.

SHEET:

1 OF 1

DRAWING NO.

231