

- (A) (1 EA.) 1/4" X 4" DIA. STEEL PLATE
- (B) (1 EA.) 4" O.D. X 3 5/8" I.D. X 3" LENGTH STD. GALV. PIPE
- (C) (1 EA.) 3 1/2" O.D. X 3" I.D. X 3'-11 3/4" LENGTH STD. GALV. PIPE
- (D) (1 EA.) 3/8" X 12" STEEL ROD

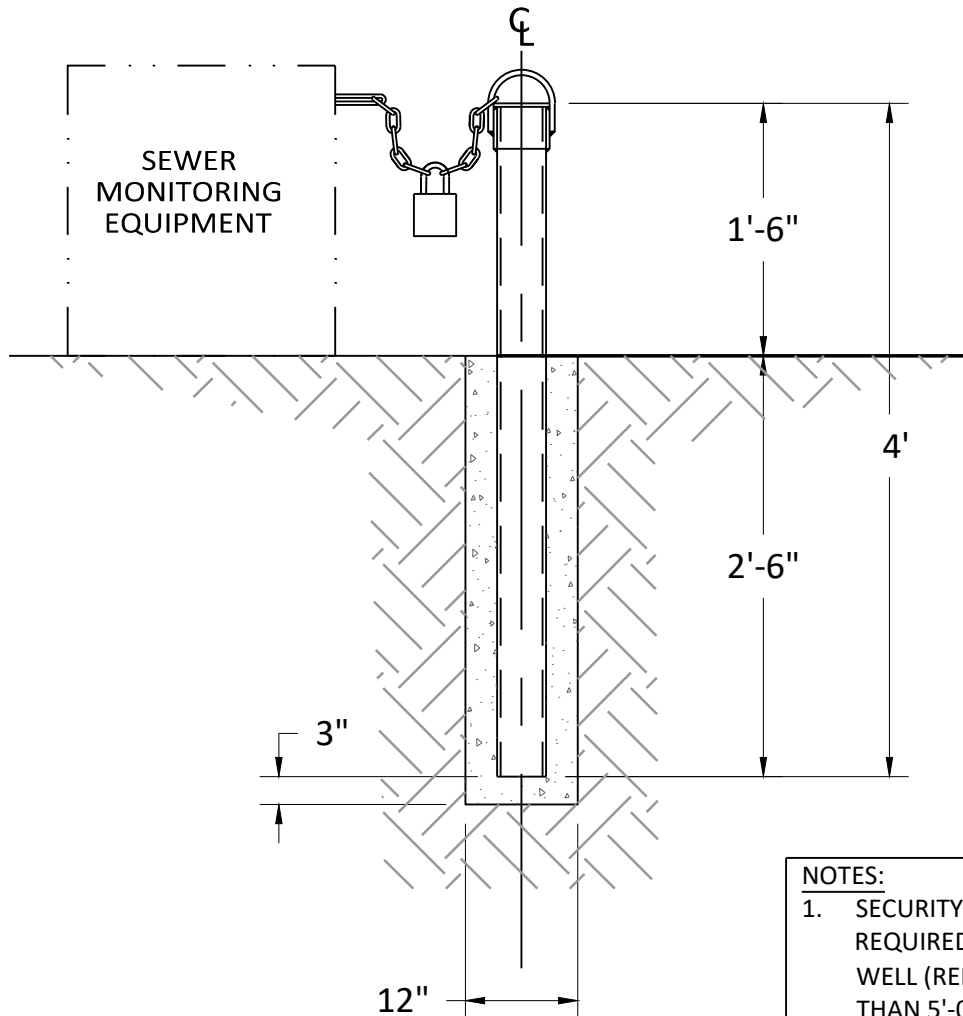

NOTES:

1. SECURITY POST WILL BE REQUIRED WHERE SAMPLING WELL (REF. DWG. 304) IS DEEPER THAN 5'-0"
2. SECURITY POST TO BE LOCATED 1'-0" TO 2'-0" FROM SAMPLING WELL